

УДК 621.316

doi:10.20998/2413-4295.2017.32.03

STUDY OF THE EFFECT OF ATMOSPHERIC OVERVOLTAGES ON OVERHEAD LINES OF MEDIUM VOLTAGE CLASSES

D. DANYLCHENKO

dept. «Electrical power transmission» National Technical University "Kharkiv Polytechnic Institute" Kharkiv, UKRAINE
email: Danylchenko.e@khp.edu.ua

ABSTRACT The article is devoted to the effect of atmospheric overvoltages on the operation of overhead lines of electrical distribution networks with protected and bare wires. The article deals with the methods of protection and their effectiveness in lightning storms used in Ukraine and in the world. The influence of lightning and line parameters on the probability of a direct lightning strike in the overhead line is considered. The technique for calculating direct lightning strikes in a line is analyzed. A new approach to the simulation of overhead lines affection by direct lightning strikes is applied by modeling the height of the orientation of the lightning. It is described the creation of a large-scale model for conducting experimental studies, with the possibility of changing the parameters of lightning (lightning current) and overhead line parameters (line voltage, type of wire). The data allowing to determine the zone of the zipper capture for the lines with the protected wires and the bare wires by the experimental method are obtained. Due to the obtained data, it is possible to more accurately determine the number of direct lightning strikes in overhead lines. The possibility of creating an overhead transmission line using a combination of bare wire and protected wires is considered. With this configuration, the striking effect of lightning on bare wires will be significantly reduced, and the bare wire in addition to the phase conductor will act as a lightning protection cable. An experimental model of a combined power transmission line has been created and its effectiveness has been experimentally confirmed. Conclusions are made about the possibility of using an overhead power line with combined wires for medium voltage classes.

Keywords: Lightning; medium-voltage overhead line; protected wires; lightning orientation height; large-scale model; lightning capture zone; combined overhead line.

ВИВЧЕННЯ ВПЛИВУ АТМОСФЕРНИХ ПЕРЕНАПРУГ НА ПОВІТРЯНІ ЛІНІЇ СЕРЕДНІХ КЛАСІВ НАПРУГИ

Д. О. ДАНИЛЬЧЕНКО

кафедра «Передачі електричної енергії» Національний Технічний Університет «Харківський Політехнічний Інститут», Харків, УКРАЇНА

АНОТАЦІЯ Стаття присвячена питанню впливу атмосферних перенапруг на роботу повітряних ліній електропередавання розподільчих електричних мереж з захищеними і голими проводами. Розглянуто вплив параметрів блискавки і лінії на ймовірність прямого удару блискавки в повітряну лінію. Проаналізовано методику розрахунку прямих ударів блискавки в лінії. Описано створення великомасштабної моделі для проведення експериментальних досліджень, з можливістю зміни параметрів блискавки і параметрів повітряної лінії. Експериментальним шляхом отримано дані, що дозволяють визначити зону захоплення блискавки для захищених проводів і голих проводів. Розглянуто можливість створення повітряної лінії електропередавання з використанням комбінації голого і захищених проводів. Експериментально підтверджено ефективність комбінованої лінії електропередавання.

Ключові слова: Блискавко вразяємість; повітряна лінія електропередавання середнього класу напруги; захищений провід; висота орієнтування блискавки; великомасштабна модель; зона захоплення блискавки; комбінована лінія електропередавання.

Introduction

The quality of power supply for most consumers directly depends on the reliability of the operation of the distribution overhead lines (OL) 6-35 kV. Among the causes of accidents and violations in the 6-35 kV overhead line, connected with the damage of insulators, poles, wires, accompanied by single-phase earth faults, arc overvoltages, short circuits and automatic shutdowns, one of the main are lightning effects. Due to the low impulse strength of linear insulation, 6-35 kV overhead lines are the most susceptible to lightning trips, since virtually all overvoltages from direct lightning strikes and a significant portion of induced overvoltages result in insulation

overlaps that are likely to be converted into a power arc of industrial frequency voltage.

Therefore, the problem of increasing the effectiveness of lightning protection and reducing the number of outages from electric power sources is very urgent, and it is given increased attention in power systems.

Traditional overvoltage arresters used for lightning protection of substation equipment can not be widely used in overhead lines, either because of technical inadequacy to the requirements, or because of the high cost.

To calculate the density of direct lightning strikes to the ground, information is used about the intensity of thunderstorm activity. In this case, it is necessary to take into account the screening of network objects by buildings,

structures, trees, etc. Screening in some cases can reduce the number of direct hits to network objects by ~ 70%.

Reliable protection is achieved if the equipment and structures have sufficiently high insulation strength or effective lightning surge protection devices are installed in the PC.

To protect the PC with a voltage of 0.4 to 35 kV from lightning overvoltages, the following applies:

- surge arresters (SA);
- high-spark arresters;
- gate and tube arresters;
- protective spark gaps.

The type, number and location of the protection devices is selected when designing specific network objects. When installing protection devices, the requirements for the value of the earth resistance are selected according to the Rules for the installation of electrical installations [1], taking into account the specific features of the systems and principles of operation of the devices (equipment) protecting against lightning overvoltages.

The task of protecting the DN 0,4 kV is to prevent people, animals and fires from breaking down due to the penetration of lightning overvoltages into the internal wiring of houses and other structures, as well as damage to the electrical equipment of 6-10 / 0.4 kV substations.

Protection of the OL middle class voltage of 6-70 kV from lightning overvoltage and the burning of protected wires is a very urgent task. In some countries, surge arresters (SA) are being used for this purpose. The main drawback, which determines the technical and economic inexpediency of using SA for lightning protection OL, is that they break down with direct lightning strikes (DLS). This extremely negative characterization is undeniable and is recognized by the developers of SA [2,3].

In Japan, extensive experience in the use of SA with an air gap for lightning protection OL 6.6 kV. These devices work relatively well only in combination with a lightning protection cable. Moreover, increasing the energy intensity of SA, in itself, does not solve the problem of their destruction from DLS. Even in the case of lightning protection cables, SA damage is observed with DLS with high currents [4]. It should be noted that this is a very expensive solution, because For reliable protection of the OL, in addition to installing the cable, it is necessary to install SA parallel to each isolator OL.

Therefore, at the present time, in fact, the only technical measure designed to reduce the damage from lightning tripping of OL 6-35 kV is automatic re-activation, the efficiency of which does not exceed 50% on average.

The real prospect of introduction in our country of distribution overhead lines with insulated wires predetermines the necessity of using any system of their lightning protection to prevent the possibility of burning wires with short-circuit power currents. Those known for the experience of using in other countries lightning protection systems for overhead lines with isolated wires

that are affordable, do not solve the problem in a complex manner, but only provide protection for the wires.

Objective

The problem of protection against lightning overvoltages OL and substations is very actual for DN with a voltage of 0.4-35 kV, since they have low impulse insulation strength in comparison with electrical installations of other voltage classes and have a long duration.

The causes of lightning overvoltages on the OL are direct lightning strikes in the line, as well as close impacts to the ground, causing induced (induced) overvoltages on the line wires.

One of the issues related to the calculation of lightning protection of overhead lines is the determination of the striking of lines by lightning. The existing estimates of the number of lightning strikes drawn by the line are empirical. The possibilities of improving this approach due to taking into account a greater number of influencing factors are practically exhausted.

Lightning resistance OL voltage 0,4 - 35 kV significantly increases when using wood insulation on the constructed OL with wooden supports, and OL with reinforced concrete and metal supports - with the use of insulating traverse.

Also, the lightning resistance OL of medium voltage classes can be increased by replacing the bare wires with protected ones. As shown earlier studies, lightning resistance OL with protected wires is less than OL with bare wires [5,6].

Methodology of determining the quantity of direct lightning strikes on the overhead lines

In order to estimate the average number of insulation overlaps on air lines of medium voltage classes for the year, it is necessary to take into account direct lightning strikes and induced overvoltages. An estimate of the number of direct lightning strikes in the transmission line, each of which will lead to insulation overlap, will be 100% for 6-35 kV lines. For induced overvoltages, it is necessary to select all lightning strikes that can occur at a distance greater than the zone of capture of a given electric transmission line, isolating from them those impacts that will lead to overvoltages that exceed the isolation voltage of the electrical transmission line [7,8].

According to normative documents, the number of direct lightning strikes (N_{DLS}) in air lines with bare and protected wires is calculated identically, according to the formula [9]:

$$N_{DLS} = 0,067 * n * 6 * H_{SUS} * L, \quad (1)$$

Where, n - number of thunderstorm hours per year; L - Length of the line, m; H_{SUS} - Wire suspension height, m.

As we see in this formula, the expression ($6 H_{SUS}$) is used, which means that the capture takes place on both sides of the line, with the capture zone in the $3 H_{SUS}$. In this case, the line voltage class is not taken into account. Nevertheless, the literature [9] gives graphs from which it can be seen that the capture zone is from $2 H_{SUS}$ to $5 H_{SUS}$ for OL with bare wires, depending on the height of the supports, i.e. class of voltage OL.

In carrying out experimental studies, the main parameter is the height of the orientation of the lightning. According to [10], the height of the orientation of the lightning (H_{or}) depends on the lightning current and is determined from the expression:

$$H_{or} = 2 I_L + 30 (1 - e^{-I_L/6.8}), \quad (2)$$

Where, I_L - lightning current; H_{or} - height of the orientation of the lightning.

Thus, we see that the height of the orientation of the lightning depends only on the value of the lightning current.

Experimental investigations on the damage of overhead line and overhead line with protected wires direct lightning strikes

The purpose of the experiments was to confirm the lightning capture zone for bare wires ($3 H_{SUS}$) and to specify the capture zone for the protected wires.

To conduct these experiments, full-scale models with corresponding similarity coefficients were created.

The general view of the model is shown in Fig. 1.

In this figure, the scheme of the experimental model

1 – support insulator;

2 – secure wire;

3 – electrode simulating lightning;

X – distance from the electrode simulating lightning to secure the wire.

As a high-voltage source, a pulse voltage generator (PVG) with a maximum voltage of 2.4 MV was used, whose appearance is shown in Fig. 2. The PVG was assembled in a half-wave circuit using 24 capacitors with a capacitance of $0.25 \mu F$ and a voltage of 100 kV. The supply of the PVG is carried out through a step-up transformer of 100 / 100,000V.

To carry out the research, the lightning current was chosen to be 20 kA and 10 kA, as the most common in the plain and mountain regions, respectively.

According to (2) of such currents, the orientation height is 43 for 10 kA and 68 meters for 20 kA. Since we carry out tests for medium voltage voltage lines of 6-35 kV, we take for consideration the typical PM 10-1 supports for 6 kV lines and 35P-5M substations for 35 kV lines. The height of the wire suspension for the PM 10-1 support is 9 m, and for the PS 35P-5M it is 15 m. As the test wires, we used the wires SIP 3 1 * 50-20 and AC-50/8.

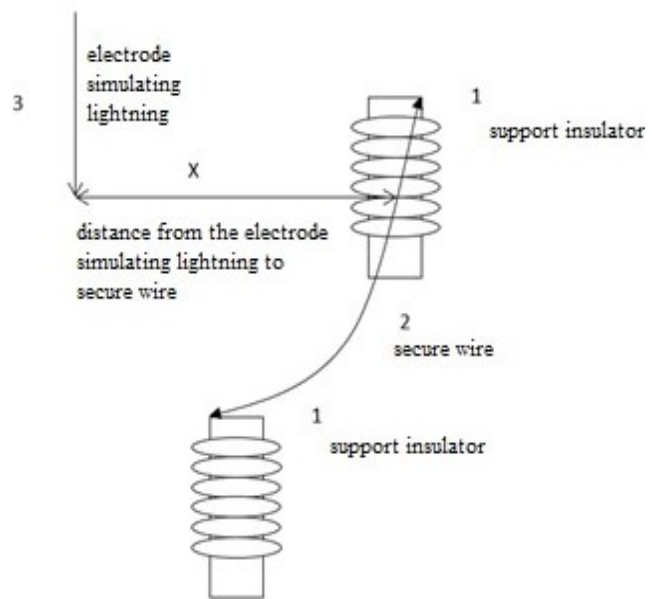

Fig. 1 – General view of the model.
1 support insulator, 2 secure wire, 3 electrode simulating lightning, X distance from the electrode simulating lightning to secure the wire.

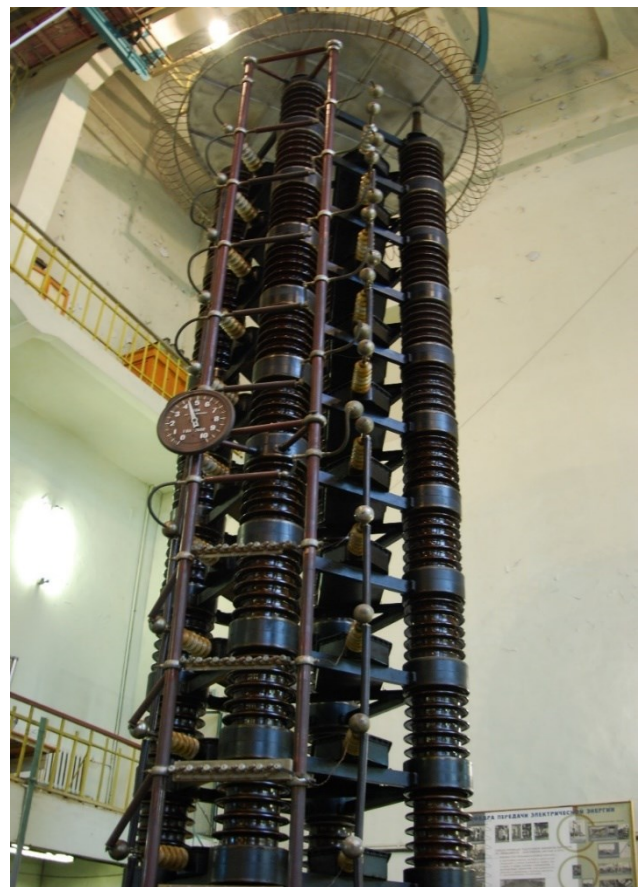

Fig. 2 – The pulse voltage generator of 2.4 MV.

Results of experimental investigations of the high-level on the determination of the zone of capture of direct lightning strikes

Based on the results of the experiments, the results in Table 1 were obtained.

Table 1 - The zone of lightning capture for different types of wires, determined experimentally, on a large-scale model

Model height of the H _{SUS} wire suspension, m	The distance from which the wire takes direct lightning strikes, m	
	SIP 3 1 * 50-20	AS – 50/8
0,1314	0,18	0,27
0,209	0,2339	0,42
0,22	0,2347	0,4225
0,345	0,393	0,62

The results of the experiments showed that for lines with protected wires the capture zone is one and a half times smaller than the area of capture of the bare wire.

Table 2 – Lightning capture zone for various wire types, classes voltage lines and different lightning current

lightning current values and voltage on the wire	The distance from which wire takes a direct lightning strikes, m.	
	SIP - 3 1 * 50-20	AS – 50/8
I _l = 10 kA; U = 6 kV	10,06	18,1
I _l = 10 kA; U = 35 kV	16,95	26,72
I _l = 20 kA; U = 6kV	11,4	17,1
I _l = 20 kA; U = 35 kV	15,96	28,73

For the constructions of the lines studied, the height of the wire suspension varied from 9 m to 15 m, and as can be seen from the obtained results, for the bare wire, the capture zone is not 3 H_{SUS}, but 2 H_{SUS}. The area of capture by wire SIP 3 1*50-20 is almost 2 times less than the zone of capture of the bare wire and does not much exceed the height of the suspension line, thus it can be said that the zone of capture of the protected wire is H_{SUS}. This fact shows that N_{DLS} for overhead lines with protected wires is much less than for overhead lines with bare wires.

Investigation of a line consisting of a bare and protected wires

As shown by previous studies, the bare wire grip zone of the bare wire is 1.5 times the protected zone of the secured lead, which allowed considering the creation of an OL with a protected and bare wire.

This allows you to consider the possibility of creating a line consisting of bare and protected wires. This will make it possible, due to the larger bare-wire capture zone, to practically eliminate DLS in the protected wires and substantially increase the lightning resistance of such a line. The increase in lightning resistance is due to the fact that only the bare wire will be affected, and therefore only it needs to be protected. We called this line a combined one, the diagram of such a line is shown in Figure 3.

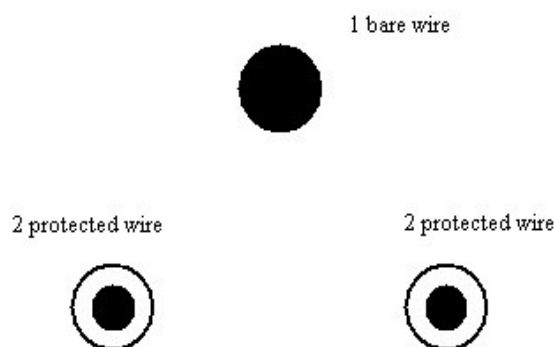

Fig. 3 - The model of the combined line. 1 bare wire, 2 - protected wires.

For a line with this configuration, experimental studies were conducted to determine the lightning impact.

Four series of experiments were performed on 100 experiments in each series. The investigations were carried out for different distances between phases and the height of the excess of the mean phase over the extreme phases.

In this case, all lightning strikes occurred in the bare wire, there was not a single lightning strike in the protected wires.

This is because the area of capture of the bare wire is much larger than the zone of capture of the protected wire. Such a line design will save considerable money, because the installation of protective equipment is required only in the middle phase with a bare wire. Moreover, in medium voltage networks, a single-phase earth fault is not an emergency. With a single-phase ground fault when an arc arises on a bare wire, the arc moves along the wire and under the action of electrodynamic forces, which leads to its rupture and corresponding extinction. In the case of a protected wire, in the event of breakdown of insulation, the arc is not able to move along the wire and burns in one place, which can lead to wire burn-out and burnout.

Conclusions

1. Overhead lines with protected wires require protection against direct lightning strikes, so determining the number of direct lightning strikes and developing a protection system is an urgent task.

2. The created large-scale model allows to carry out studies of the lightning severity of overhead lines of medium voltage classes by direct lightning strikes.

3. The conducted experiments showed that the existing methods for determining direct lightning strikes in overhead lines require clarification.

4. The obtained results made it possible to clarify the magnitude of the zipper capture zone for overhead lines with protected wires.

5. An overhead line model having both a bare wire and a protected wires was investigated. It is experimentally confirmed that such an overhead line will significantly reduce the probability of hitting the protected wires with a direct lightning strike.

Bibliography

1. Правила улаштування електроустановок / Міністерство енергетики та вугільної промисловості України, Харків, Форт, 2017.
2. **Kuffel, E.** High Voltage Engineering / **E. Kuffel, W. S. Zaengl** – Pergamon Press, Great Britain, 2000. - p. 554.
3. **Short, T. A.** Monitoring Results of the Effectiveness of Surge Arrester Spacings on Distribution Line Protection / **T. A. Short, R. H. Ammon** // *IEEE Trans. On Power Delivery*. – 1999. – V. 14, No. 3. – P. 1142-1150. – doi: 10.1109/61.772385.
4. **Nakada, K.** Energy Absorption of Surge Arresters on Power Distribution Lines due to Direct Lightning Strokes-Effects of an Overhead Ground Wire and Installation Position of Surge Arresters / **K. Nakada et. al.** // *IEEE Transactions on Power Delivery*. – 1997. – V. 12, No. 4. – P. 1779-1785. – doi: 10.1109/61.634205.
5. **Sergey, S.** Defeat of overhead lines transmission networks with protected wires from lightning strike / **S. Sergey, D. Dmitriy** // *Applied Physics (YSF), 2015 International Young Scientists Forum on*. – IEEE, 2015. – P. 1-4. – doi: 10.1109/ysf.2015.7333228.
6. **Шевченко, С.Ю.** Поражаемость воздушных линий распределительных сетей с защищенными проводами грозвыми разрядами. / **С.Ю. Шевченко, Б.Ф. Ермоленко, Д.А. Данильченко, С.И. Дривецкий** // – *Вісник Національного технічного університету «ХПІ»*. Збірник наукових праць. Серія: Енергетика: надійність та енергоефективність. – Х. : НТУ «ХПІ». – 2016. - №3 (1175). – С. 101 – 107.
7. **Rizk, Farouk A.M.** Modeling of Substation Shielding Against Direct Lightning Strikes / **Farouk A.M. Rizk** // *IEEE*

- Trans. on Electromagnetic compatibility*. – 2010. – V. 52, No. 3. – P. 664. – doi: 10.1109/temc.2010.2046903.
8. **Cooray, V.** Attractive radius and the volume of protection of vertical and horizontal conductors evaluated using a self consistent leader inception and propagation model – SLIM. / **V. Cooray, M. Becerra** // *Proc. of 30th Int. Conf. on Lightning Protection. Italy* (Cagliari), 2010, 1062 p.
9. РД 153-34.3-35.125-99 Рекомендации по защите электрических сетей от молнии и внутреннего перенапряжения 6 - 1150 кВ.
10. **Гуль, В. И.** Координация изоляции и перенапряжения в электрических высоковольтных сетях / **Гуль В. И., Нижевский В. И., Хоменко, И. В. Шевченко С. Ю., Чевычелов В.А.** // Харьков. – 2009. – 270 с.

Bibliography (transliterated)

1. Pravila ulashtuvannya elektroustanovok / MInIsterstvo energetiki ta vuglinoi promislovosti Ukraine, Kharkiv, Fort, 2017.
2. **Kuffel, E., Zaengl, W. S.** High Voltage Engineering. Pergamon Press, Great Britain, 2000, 554.
3. **Short, T. A., Ammon, R. H.** Monitoring Results of the Effectiveness of Surge Arrester Spacings on Distribution Line Protection, *IEEE Trans. On Power Delivery*, 1999, Vol. 14, No. 3, 1142-1150, doi: 10.1109/61.772385.
4. **Nakada K. et. al.** Energy Absorption of Surge Arresters on Power Distribution Lines due to Direct Lightning Strokes-Effects of an Overhead Ground Wire and Installation Position of Surge Arresters, *IEEE Transactions on Power Delivery*, 1997, Vol. 12, No. 4, 1779-1785, doi: 10.1109/61.634205.
5. **Sergey, S., Dmitriy, D.** Defeat of overhead lines transmission networks with protected wires from lightning strike. *Applied Physics (YSF), 2015 International Young Scientists Forum on*. IEEE, 2015, 1-4, doi: 10.1109/ysf.2015.7333228.
6. **Shevchenko, S., Ermolenko, B., Danylchenko, D., Dryvetsky, S.** Susceptibility of overhead lines of distribution networks with protected wires by lightning discharges, *Bulletin of the National Technical University "KhPI". Collection of scientific papers. Series: Power reliability and energy efficiency*. - Kh: NTU "KhPI", 2016, №3 (1175), 101 - 107.
7. **Rizk, Farouk, A.M.** Modeling of Substation Shielding Against Direct Lightning Strikes, *IEEE Trans. on Electromagnetic compatibility*, 2010, 52, No. 3, 664 p., doi: 10.1109/temc.2010.2046903.
8. **Cooray, V., Becerra, M.** Attractive radius and the volume of protection of vertical and horizontal conductors evaluated using a self consistent leader inception and propagation model – SLIM, *Proc. of 30th Int. Conf. on Lightning Protection. Italy* (Cagliari), 2010, 1062 p.
9. RD 153-34.3-35.125-99 Guidelines for the protection of electrical networks 6 - 1150 kV lightning and internal overvoltage.
10. **Gul, V., Nizhevsky, V., Khomenko, I., Shevchenko, S., Chevychelov, V.** Insulation coordination and overvoltage in electrical transmission systems, Kharkiv, 2009. p. 270.

Сведения об авторах (About authors)

Danylchenko Dmytro – graduate student, assistant dept. «Electrical power transmission» National Technical University "Kharkiv Polytechnic Institute", Kharkiv, Ukraine; e-mail: Danylchenko.e@khp.edu.ua.

Данильченко Дмитро Олексійович – аспірант, асистент кафедри «Передача електричної енергії» Національний технічний університет «Харківський політехнічний інститут», м. Харків, Україна; e-mail: Danylchenko.e@khp.edu.ua.

Please cite this article as:

Danylchenko, D. Study of the effect of atmospheric overvoltages on overhead lines of medium voltage classes. *Bulletin of NTU "KhPI". Series: New solutions in modern technologies.* – Kharkiv: NTU "KhPI", 2017, **32**(1254), 19-24, doi:10.20998/2413-4295.2017.32.03.

Будь ласка, посилайтеся на цю статтю наступним чином:

Данильченко, Д. О. Вивчення впливу атмосферних перенапруг на повітряні лінії середніх класів напруги / **Д. О. Данильченко** // *Вісник НТУ «ХПІ», Серія: Нові рішення в сучасних технологіях.* – Харків: НТУ «ХПІ». – 2017. – № 32 (1254). – С. 19-24. – doi:10.20998/2413-4295.2017.32.03.

Пожалуйста, ссылайтесь на эту статью следующим образом:

Данильченко, Д. А. Изучение влияния атмосферных перенапряжений на воздушные линии средних классов напряжения / **Д.А. Данильченко** // *Вестник НТУ «ХПИ», Серія: Новые решения в современных технологиях.* – Харьков: НТУ «ХПИ». – 2017. – № 32 (1254). – С. 19-24. – doi:10.20998/2413-4295.2017.32.03.

АННОТАЦИЯ Стаття посвящена вопросу влияния атмосферных перенапряжений на работу воздушных линий распределительных электрических сетей с защищенными и голыми проводами. Рассмотрено влияние параметров молнии и линии на вероятность прямого удара молнии в воздушную линию. Проанализирована методика расчета прямых ударов молнии в линии. Описано создание крупномасштабной модели для проведения экспериментальных исследований, с возможностью изменения параметров молнии и параметров воздушной линии. Получены данные позволяющие определить зону захвата молнии для линий с защищенными проводами и голыми проводами экспериментальным путем. Создана экспериментальная модель комбинированной линии электропередачи и экспериментально подтверждена её эффективность.

Ключевые слова: Грозопоражаемость; воздушная линия среднего класса напряжения; защищенные провода; высота ориентировки молнии; крупномасштабная модель; зона захвата молнии; комбинированная линия электропередачи.

Поступила (received) 18.09.2017